

THIRD ANGLE PROJECTION  
ALL DIMENSIONS IN mm  
DO NOT SCALE

NOTES:

PIGTAIL MANIFOLDS TO BE MANUFACTURED, ENSURING DIMENSIONS SHOWN ARE ACHIEVABLE.

PIGTAIL IS ROUGHLY  $\phi$  40MM IN DIAMETER.

MANIFOLD TO BE NEATLY AND ACCURATELY PRODUCED.

MANIFOLD TO BE HELIUM LEAK TESTED TO  $<1 \times 10^{-9}$  mBar l/s.

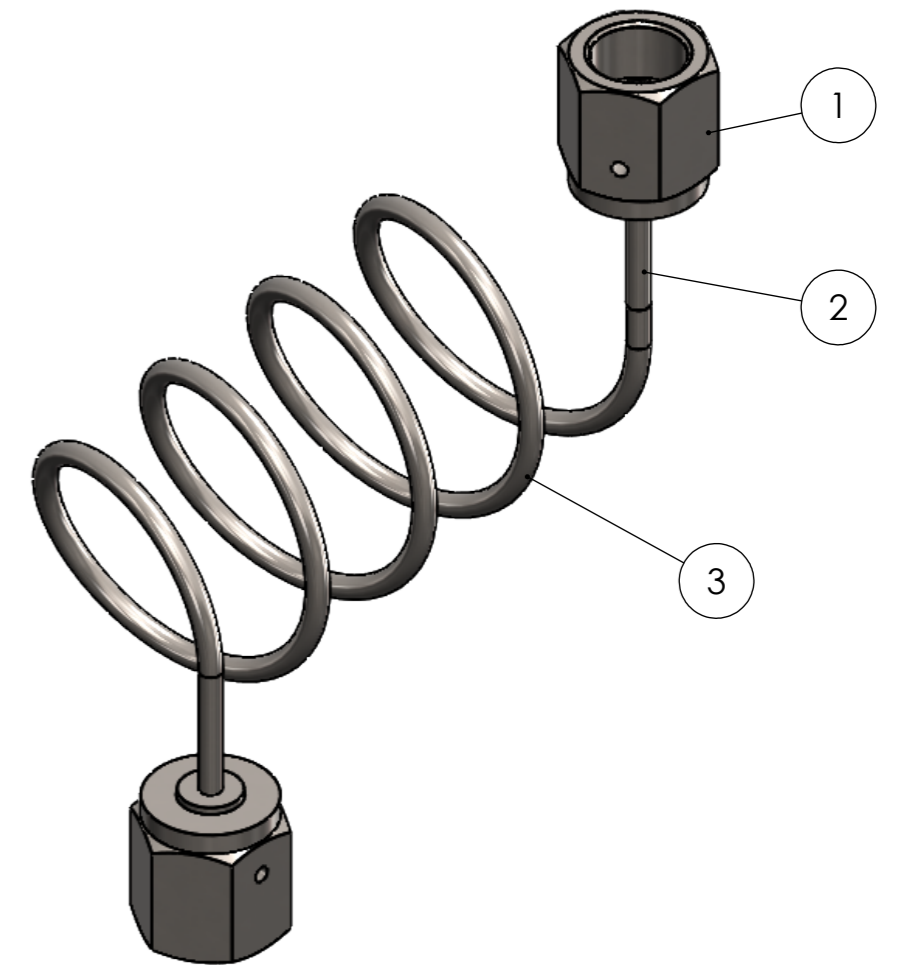
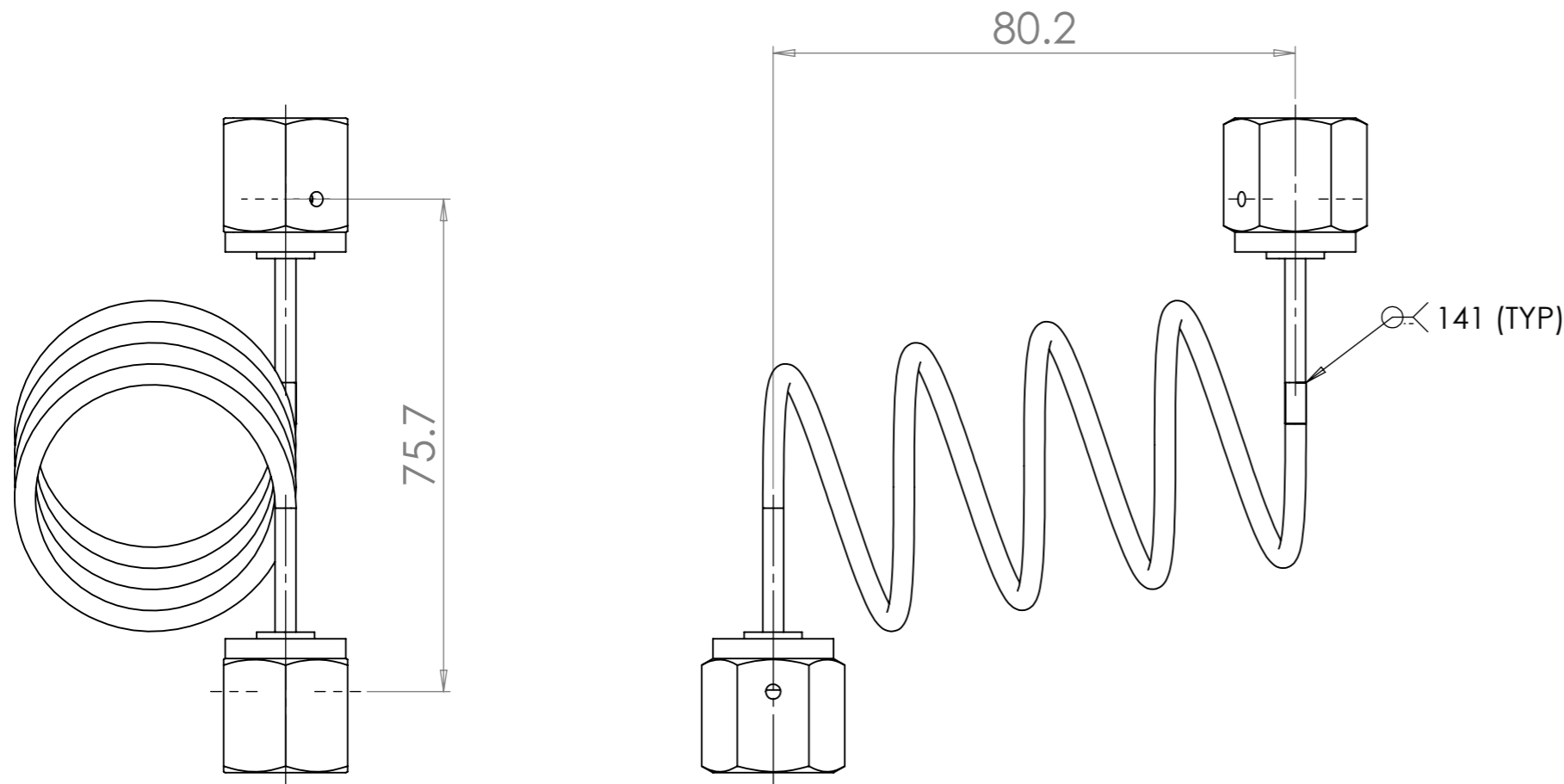

ITEM NO.	PART NUMBER	DESCRIPTION	VENDOR	QTY.
1	SS-4-VCR-1	1/4" VCR Female Nut	Swagelok	2
2	6LV-4-VCR-3S-2TB7	1/4" to 1/8" Gland	Swagelok	2
3	1/8" OD Tube	1/8" OD Tube, 0.028" WT	Stock	1

**TOLERANCES:**  
(UNLESS OTHERWISE STATED)  
X ----- +/- 1  
X.X ----- +/- 0.5  
X.XX ----- +/- 0.1  
Surface Finish Ra 1.6

**FINISH:**  
Clean

SHEET SIZE: A3  
REMOVE ALL SHARP EDGES AND BURRS

1	ISSUED TO PRODUCTION	16/05/2017
REV	MODIFICATION	DATE

ISO 128

**MATERIAL:**  
See BoM

**TITLE:** Female to Female 1/8" Bubbler Manifold  
**DRAWING NUMBER:** 7478